

NOTICE OF SERVICE INTERRUPTION/WORK FORM

Date of Request (yyyy/mm/dd): _____		Requester: _____	
Start Date – End			
Start Date (yyyy/mm/dd) _____	Time (s) _____	Notes _____ _____	
End Date (yyyy/mm/dd) _____	Time (s) _____		
Building(s) Affected:		1: _____	2: _____
		3: _____	4: _____
Areas/Rooms Affected: _____			
Service to be interrupted:		1: _____	2: _____
		3: _____	4: _____
Description/Reason for Project:			
Contractor: _____		Phone #: _____	
Contractor/Project Managers: _____		Phone #: _____	
Should you have any questions or concerns, please contact			
Notes:			



**NOT FOR
CONSTRUCTION**

OUTLINE OF UNIVERSITY
OF WINDSOR FITNESS
CENTRE

PROPOSED 2ft
MICROWAVE AT
Az. 317.73°

PROPOSED
4-STONE
ANTENNA
BALLAST
MOUNT

PROPOSED CONDUIT TO
ROOF HATCH OPENING ON
RUBBERIZED SLEEPERS
SPACED @ 40" APART

OUTLINE OF UNIVERSITY
OF WINDSOR FITNESS
CENTRE

PROPOSED 4-STONE
ANTENNA BALLAST
MOUNT
w/ 2ft MICROWAVE AT
Az. 317.73°

PROPOSED CONDUIT TO
ROOF HATCH OPENING ON
RUBBERIZED SLEEPERS
SPACED @ 40" APART

Rev.	Description	Dwn	Chk	App	Date
------	-------------	-----	-----	-----	------



65 Raglin Road
Cambridge, Ontario
N1T 1X9
Phone: 519-621-8840
Fax: 519-621-4605

Copyright - duplication, recording, disclosure, and use is prohibited without the written consent of SKYWARD TOWERS INC.

Drawing Reference:

Drawing Title
**PROPOSED
2ft MICROWAVE MOUNT**

**UNIVERSITY OF WINDSOR
FITNESS CENTRE**

TELUS MOBILITY ON4075

Drawn By: KF	Checked By: BT	Approved By:
-----------------	-------------------	--------------

Skyward Job No.: 9834	Date: 21 JUN 19	Rev: 0
--------------------------	--------------------	-----------

Drawing No.:
9834-ON4075-01MW-E01

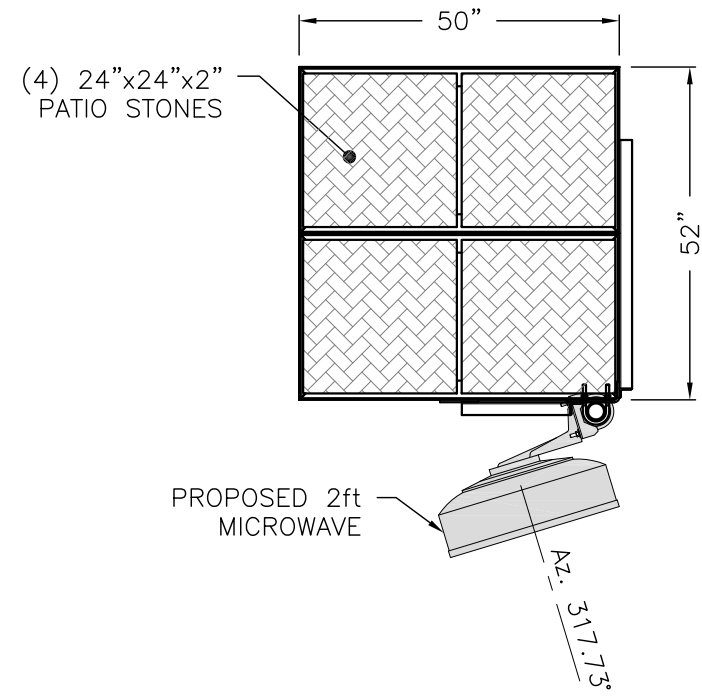

PLAN VIEW

NOT FOR CONSTRUCTION

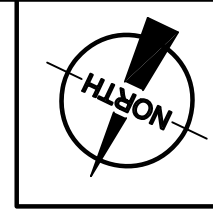

Rev.	Description	Dwn	Chk	App	Date

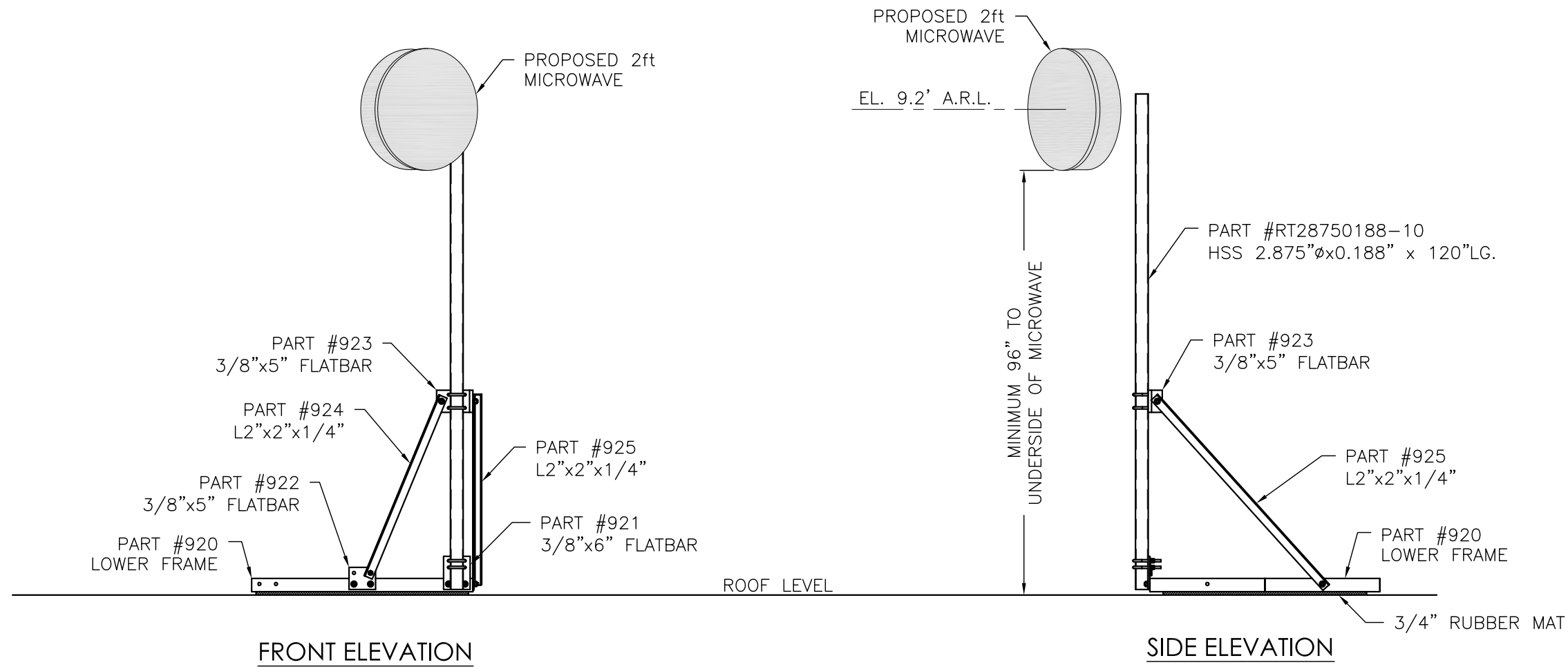

Skyward Towers
 65 Raglin Road
 Cambridge, Ontario
 N1T 1X9
 Phone: 519-621-8840
 Fax: 519-621-4605

Copyright - duplication, recording, disclosure, and use is prohibited without the written consent of SKYWARD TOWERS INC.

Drawing Reference:

Drawing Title
PROPOSED 2ft MICROWAVE BALLAST MOUNT

UNIVERSITY OF WINDSOR
 FITNESS CENTRE

TELUS MOBILITY, ON4075

Drawn By: KF	Checked By: BT	Approved By:
Skyward Job No.: 9834	Date: 21 JUN 19	Rev: 0

Drawing No.:
 9834-ON4075-01MW-E02